

B-B

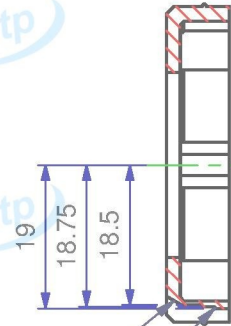

1.15 X 60° Smusso
0.25 X 45° Smusso

1 X 45° Smusso



C

C (5)

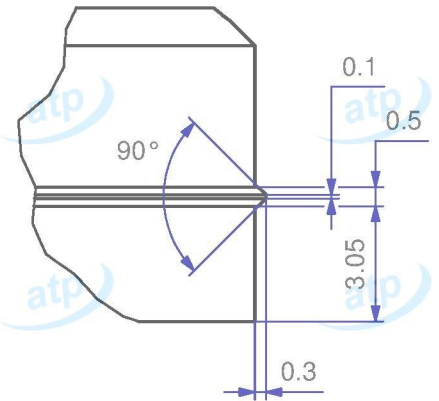

n°4 fori uguali

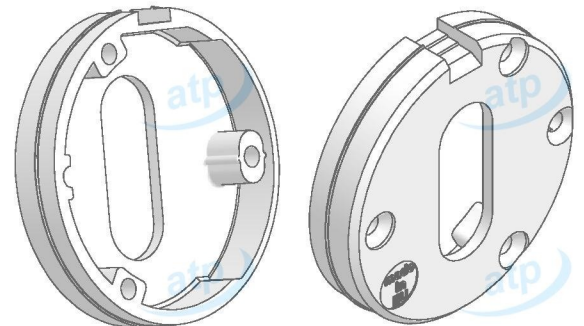
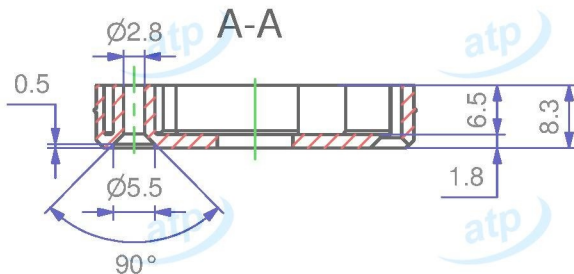
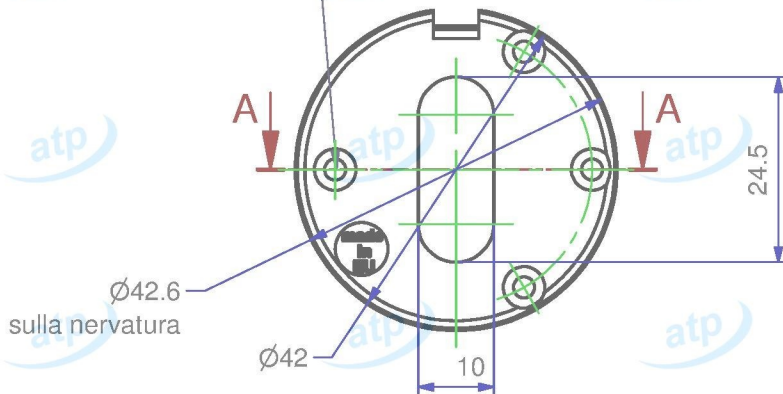

Data	2015/03/03	Quote espresse in mm e riferite AL PEZZO	Prodotto campione validato	NO	atp di f. garzoni via del tram 8 -I- 25070 Lavenone -Bs - Italy www.atp.it info@atp.it ufficiotecnico@atp.it		
Descrizione	Bocchetta d 45x9 mm, fori testa vite, foro OB 8,5x20 mm				Foglio	Scala	
Codice articolo	MKBT4590V0/00	Codice cliente	atp	Disegnatore	Claudio f	Approvato da	
Materiale	PP COPOLIMERO	Trattamento		Volume mm³	~ 3563	Peso g.	~ 3.3
atp si riserva, a termini di legge, la proprietà di questo disegno con divieto di riprodurlo o di renderlo noto a terzi senza sua autorizzazione							Per quote senza tolleranza UNI EN 22768-m
							Mod.07.03/P04